



Vx350i

Uncompromising performance and quality

Vx350i is an industrial thermal transfer overprinting (TTO) coding solution capable of printing large size, high-resolution codes, text, and images on flexible foils, films, and labels, making it suitable for a wide range of flexible packaging applications. The robust **Vx350i** is the obvious choice across industries such as pharma, life sciences, and food, on lines with high-production throughput, and applications requiring complex dynamic codes containing a significant amount of variable data.



Exceptional performance

- ◆ The **Vx350i** meets current and future production needs with print rates of up to 8.3 prints per second, offering reliable, high-speed printing.
- ◆ Prints clear, machine-readable 2D codes including QR and Data Matrix codes, for improved supply chain traceability and transparency, and compliance with industry standards including the GS1 Digital Link.



Industrial robustness

- ◆ Engineered to seamlessly integrate into any packaging machinery, including labelers, flow wrappers, VFFS, and HFFS (vertical and horizontal form, fill, and seal).
- ◆ The easy-to-thread cassette is complemented by a washdown cassette and connector protection cover for harsh environments.

Customer centric

- ◆ The direct-drive printer provides clever ribbon-saving modes, helping to decrease ribbon consumption by up to 60% per print.
- ◆ Long length ribbon rolls (up to 1200m) provides increased throughput and minimal factory downtime due to ribbon changes.

www.dominoindia.com

Domino. Do more.



A complete solution



Our services are designed to provide operational insight so you can reduce downtime and maximise production efficiency

Smart production

Gain operational insight by connecting your printer to **Domino Cloud**. Obtain production analytics dashboards and receive system error alerts. **Domino Cloud** provides you with the information you need to run your operations more efficiently.

Central label management

Domino Automation easily integrates into your manufacturing process as well as your ERP/ MES systems. It makes automatic changeovers safe and simple, helping you to reduce waste and drive sustainability initiatives while increasing productivity and efficiency.

Automatic code inspection

Ensure every code that leaves your factory is present and correct, and free up operator time. With the **R-Series**, Domino's range of vision control systems, you can automate your code inspection to validate code presence, placement, and readability.

Operational support

Our **SafeGuard** extended warranty packages provide high-quality, on-site assistance and augmented reality-enabled remote guidance from our engineers. **SafeGuard** helps to ensure we can be with you when you need us most.



Looking for more connectivity options and easy integration? Configure your **Vx350i** with a well-equipped interface box.

Operating in harsh environments? Configure your **Vx350i** with a washdown kit to achieve IP55.



Technical specification **Vx350i**

Printer	Intermittent mode (IM)	Continuous mode (CM)
Printing modes	✓	✓
Print resolution	300dpi	
Printer variants	Left hand and Right hand	
Print speed	Up to 600mm/sec	10 to 750mm/sec (standard) 10 to 1200mm/sec (enhanced pack)
Maximum repeat rate	6 prints/sec (standard) 8.3 prints/sec (enhanced pack)	
Print area	53x75mm	53x500mm (standard) 53x750mm (enhanced pack)
Printhead width	53mm	
Distance from start print area to rear cover	113.3mm (117mm when including space for cable routing)	
Ribbon length	Maximum 1200m (AR)	
Ribbons widths	34mm and 55mm	
Connectors Printer	2 USB, 1 GPIO, 1 encoder	
Connectors Interface box	2 USB, 1 RJ45, 2 GPIO, 1 encoder, 2 IX ports, 1 to connect printer	
Supported code formats	Code128, Data Matrix, GS1-128, GS1(DB) Expanded Stacked, QR-Code, UPCA	
Printer weight	9.1Kg	
Cassette weight (excl ribbons)	1.7Kg	
Fully electric	✓	Compressed air not required
Electrical supply	Printer standalone: 48V, 6.3A, 300W Printer with interface box: 100 to 240VAC, 50/60Hz	
Operating temperature/humidity	5 to 40°C (41 to 104°F) / 10% to 90% RH	
Ingress protection rating	IP55 when washdown cover is installed (non operational)	
Ribbon saving modes	Economy, Retraction, Column	Economy, Retraction, Column, Stop-mid-print
Protocol (OEM integration)	Dynamark	
Tablet connectivity	Via Wi-Fi dongle	
PC connectivity	Via Ethernet cable	
TouchPanel6 (optional UI)	10.1" touchscreen Multi-language support ✓	
Mounting brackets (optional)	Complete range of mounting brackets to suit your needs	

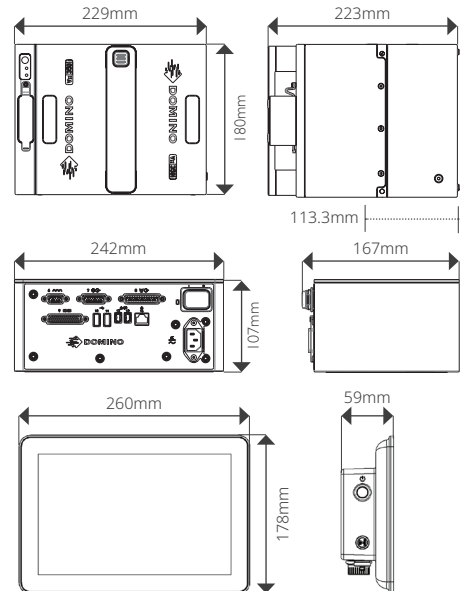

CONTACT US

TALK TO AN EXPERT

+91-900 900 6612
 enquiry@dominoindia.com
 www.domino-printing.com



KNOW MORE

Domino Printech India LLP, 117, Sector-8, IMT Manesar, Gurugram, Haryana, India - 122050

Vx350i/1124 IN

All performance related figures and claims quoted in this document were obtained under specific conditions and may only be replicated under similar conditions. For specific product details, you should contact your Domino Sales Advisor. This document does not form part of any terms and conditions between you and Domino.