

Mx350i-S & SP

The easy choice for your labelling

The **Mx-Series** ensures you are equipped with an automated print and apply system that prints and applies labels with variable data accurately and consistently, reducing the risks of human error. This is crucial in all industries where precise labelling is essential for product tracking, compliance, and quality control.

With the **Mx350i-S** and **Mx350i-SP**, we can offer a bespoke installation suited to your manufacturing site, making sure to streamline your labelling process whether you need a label on the front, rear, top, side, or corner of a product or package.

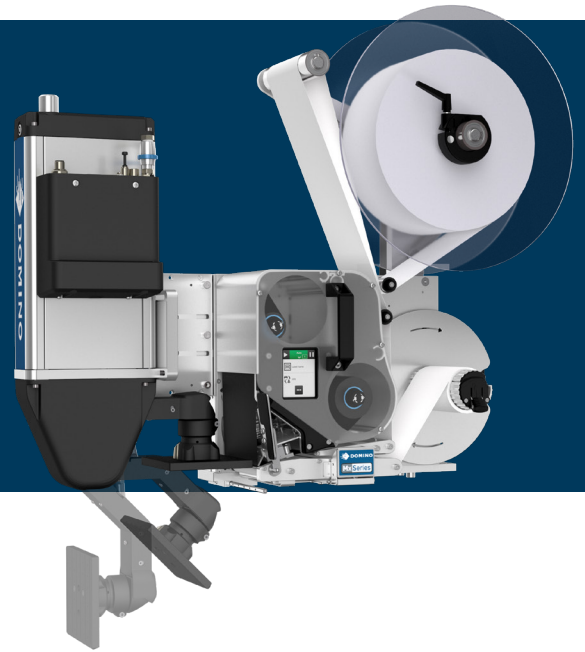

Easy to integrate

- ◆ The **Mx350i's** advanced connectivity options allow for seamless integration with ERP, WMS, and MES systems in your factory.
- ◆ **Mx350i-S** and **Mx350i-SP** are compact and versatile printing and labelling systems that can be easily integrated into any production line. Available in both left- and right-hand variants, it can be used in a variety of different applications.



Easy to use

- ◆ The integrated UI and optional remote 10-inch touchscreen are both designed to be simple and easy to navigate.
- ◆ The robust design and smart functionality of the **Mx350i-S** and **Mx350i-SP** minimises the time needed for media changes and maintenance, helping to maximise your production uptime.

Easy to adapt

- ◆ With three different running modes you can easily switch from labelling one side of a product, to labelling two sides, or a corner wrap application.
- ◆ The **Mx350i-S** and **Mx350i-SP** are built to last, with the flexibility to adapt to your evolving labelling needs without the need for costly investments.

www.dominoindia.com

Domino. Do more.



A complete solution for all labelling needs



Our services are designed to provide operational insight so you can eliminate downtime and maximise production efficiency

Operational support

Our extended warranty packages provide high-quality, on-site assistance and augmented reality-enabled remote guidance from our engineers. **SafeGuard** helps to ensure we can be with you when you need us most.

Automatic code inspection

Ensure every code that leaves your factory is present and correct, and free up operator time. The **R-Series**, Domino's range of vision control systems, can automate your code inspection to validate code presence, placement, and readability.

Control software

Control your product codes from a central location and streamline product changeovers. Domino Automation uses standard communication protocols and can be integrated into existing ERP systems.

High-quality consumables

Domino provides an extensive range of high-quality consumables for both general purpose and niche requirements. To achieve brilliant results and protect your printer, only use genuine Domino consumables.



Technical specification

Model	Mx350i-S4 & SP4	Mx350i-S6 & SP6
Print width	4-inch (108mm)	6-inch (162mm)
Print technology	Thermal transfer / Direct thermal	
Print resolution	12 dots/mm (300dpi)	
Printer variants	Left hand or Right hand	
Max print speed	400mm/s	250mm/s
Distance to product (D)	130mm model: 10-220mm 270mm model: 10-360mm	
Product motion	Moving	
Apply method	Tamp (swing)	
Label position(s)		
Recommended label width	25-110mm	25-150mm
Recommended label length	15-210mm	
Label & ribbon roll length	Up to 600m	
Input voltage	90-250VAC 50/60Hz	
Communication	4x Ethernet, TCP/IP, 2x USB-A, 1x USB-B	
I/Os (configurable)	12 inputs and 12 outputs	

Dimensions

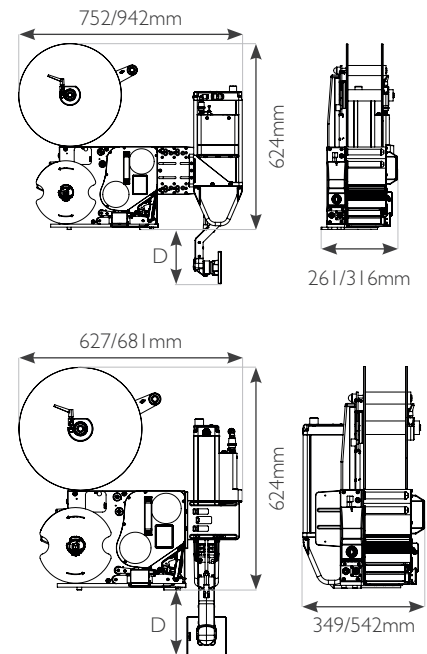

CONTACT US

TALK TO AN EXPERT

- +91-900 900 6612
- enquiry@dominoindia.com
- www.dominoindia.com

Domino Printech India LLP, I17, Sector - 8, IMT Manesar, Gurugram, Haryana, India - 122050