

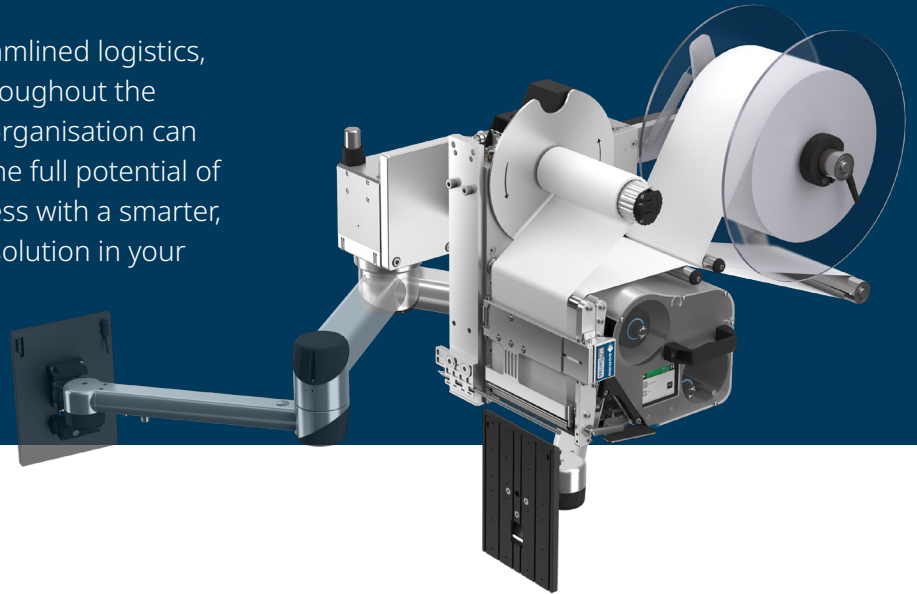

Mx350i-eP

Keeps the world moving

Pallet labeling is the cornerstone of streamlined logistics, driving efficiency, precision, and trust throughout the supply chain. With the **Mx350i-eP** your organisation can ensure seamless operation and unlock the full potential of the logistics process. Elevate your business with a smarter, safer, and more compact pallet labeling solution in your factory or warehouse.



Engineered for Efficiency

- ◆ With energy efficiency, reduced air usage, and a compact footprint, the **Mx350i-eP** integrates seamlessly into production lines, supporting your sustainability goals while operating quickly and efficiently.
- ◆ The **Mx350i-eP's** advanced connectivity ensures seamless integration with ERP, WMS, and MES systems, streamlining data flow and boosting supply chain efficiency.



Engineered for Safety

- ◆ The **Mx350i-eP** is designed for safety, providing an operator-friendly solution that ensures safe and easy access to daily operations.
- ◆ With built-in features like arm collision detection and a design that eliminates pinch risks, the pallet labeler is fully compliant for installation without any surrounding guarding.

Engineered for Flexibility

- ◆ Featuring four labeling patterns that can be combined in various configurations, and utilizing a flexible, electric arm for enhanced versatility.
- ◆ The **Mx350i-eP** offers exceptional adaptability, enabling you to apply between one and four labels on full or half pallets. It also supports partial pallet labeling, featuring a controlled and convenient manual label pick-up.

www.domino-na.com

Domino. Do more.



A complete solution for all labeling needs



Our services are designed to provide operational insight so you can reduce downtime and maximize production efficiency

Operational support

Our extended warranty packages provide high-quality, on-site assistance and augmented reality-enabled remote guidance from our engineers. **SafeGuard** helps to ensure we can be with you when you need us most.

Code verification

After the label is applied to the pallet, the integrated camera automatically scans and verifies the readability of the 1D or 2D barcode, ensuring that each pallet leaving your facility has a correct and clearly visible label.

Central label management

Domino Automation easily integrates into your manufacturing process as well as your ERP/MES systems. It makes automatic changeovers safe and simple, helping you to reduce waste and drive sustainability initiatives while increasing productivity and efficiency.

Smart production

Gain operational insight by connecting your printer to **Domino Cloud**. Obtain production analytics dashboards and receive system error alerts. **Domino Cloud** provides you with the information you need to run your operations more efficiently.



Technical specification **Mx350i-eP**

Model	Mx350i-eP6
Print width	6-inch (162mm)
Print technology	Thermal transfer / Direct thermal
Print resolution	12 dots/mm (300dpi)
Printer variants	Left hand or Right hand
Max print speed	250mm/s
Highest rec. cycle speed	10 labels per minute
Max stroke length	600mm
Product motion	Stationary
Apply method	Tamp by electric flexible arm
Label position	4 (8) different apply patterns supported 
Recommended label width	25-150mm (1-6")
Recommended label length	15-210mm (0.6-8.3")
Label & ribbon roll length	Up to 600m
Input voltage	90-250VAC 50/60Hz
Communication	4x Ethernet, TCP/IP, 2x USB-A, 1x USB-B
I/Os (configurable)	12 inputs and 12 outputs
TouchPanel 6 (optional UI)	10.1-inch touchscreen Multi-language support ✓

Dimensions

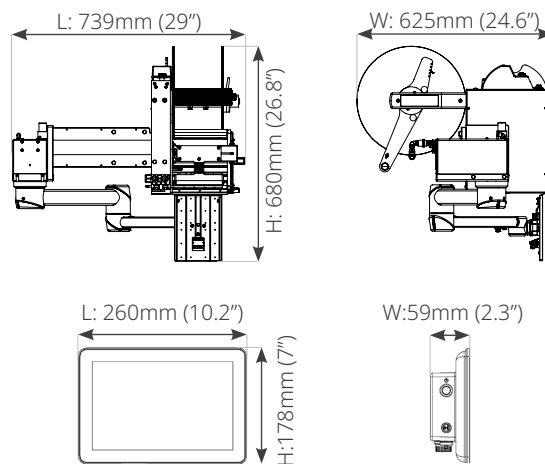

TALK TO AN EXPERT

- 800.444.4512
- solutions@domino-na.com
- www.domino-na.com

CONTACT US