



Dx-Series CO₂ Laser Coders

Coding with the energy of light

Laser solutions you can count on:
fast, flexible, and built to last

Domino. Do more.

Flexibility, reliability, and performance



Track and trace, anti-counterfeiting, and increased customer interaction, alongside waste reduction and the move to more sustainable solutions, are key topics in modern manufacturing.

With **Dx-Series** CO₂ laser coders you have a future-proof solution for the coding requirements of your manufacturing environment. **Dx-Series** lasers support compliance to GSI standards and the move to larger, more complex 2D machine-readable code formats, including QR codes powered by GSI.

For line integration:

- ◆ More than 50 standard beam delivery options, a 360° rotatable scanhead, and customization options for specific needs.
- ◆ Seamless integration into ERP, WMS, and MES systems.
- ◆ Web-based user interface and easy operation via an intuitive HMI.

For performance:

- ◆ Advanced coding algorithm increases speed by up to 30% while maintaining superior code quality.
- ◆ Options for coding automation, **R-Series** vision control, and near real-time remote monitoring and diagnostics via Domino's cloud-based services help to ensure only perfectly coded products enter the supply chain.

For tough environments:

- ◆ Dusty, wet, and sticky environments are no problem with IP54/IP65 certified printheads and IP55 certified controller.
- ◆ Performs at 45°C ambient temperature.



Optimized efficiency

Innovative coding technology leads to exceptional performance: for the **Dx-Series** we have developed intelligent printheads, implemented advanced digital scanhead technology, and optimized the coding algorithms. These innovations achieve significantly faster compilation times. On a production line that translates to significantly higher coding speed and significantly better code quality*.

*Coding speed depends on the individual application; **Dx-Series** has been benchmarked against Domino **D-Series**

Permanent traceability with excellent quality codes

The **Dx-Series** is a versatile solution for a range of substrates in a wide variety of applications, across industries such as food, beverage, life sciences, cosmetics, and others.

Our laser specialists are on hand to help define the ideal configuration for your specific application.



Label replacement: unlimited lines of text and complex 2D codes to support the move to labelless.



Glass: the **Dx-Series** codes at high speeds, in excellent quality even on tough substrates.



Films: ideal for pots and stickpacks: large marking fields, pin-sharp small characters.



Cardboard: Smart 2D coding that's ready for GSI Sunrise: variable data helps unlock the full potential and supports authentication and anti-counterfeiting.



PET: ideal for the beverage industry, designed for high production rates and with optional IP65 certified protection.



Paper based wrappers: marking algorithms that are gentle enough to code modern, sustainable packaging materials while keeping protective barriers intact.



Labels: **Dx-Series** can be seamlessly integrated into labeling machinery for high-precision labels.



Plastic blisters: pin-sharp codes, impressive reliability, and consistent uptime at high production speeds.



Cork: graphics and logos in brilliant clarity to complement your brand.



Paper label: glass bottle label marking at speeds of up to 70-90k bph.



Glass: designed for toughened and laminated glass panes.



Coated metal: precise marking on convex or concave surfaces.

Advanced technology

Domino has over 30 years experience in developing expert laser coding systems that have a reputation for quality and longevity. Utilizing latest advancements and with attention to detail, our latest generation CO₂ laser coders are designed to integrate seamlessly into production environments; make installation, operation, and maintenance simple; and deliver a superior product coding solution.



The intuitive web-based user interface runs on all devices with standard browsers and is common across Domino's x-generation product portfolio. A modern touch panel option is also available.

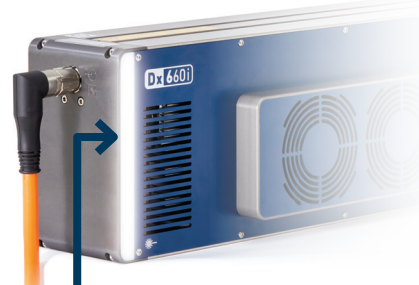

Because details matter, we have thought of little things that make integration and operation easy, including angled printhead and controller conduit options. The prominent LED strip on the printhead offers instant visibility, clearly indicating whether the laser is powered on.

Adjustable and telescopic beam deliveries, a 360° rotatable scanhead and the option to customize enable integration on almost any line. An optional IP65 certified printhead and IP55 controller mean you don't have to worry about wet, sticky, or dusty environments.

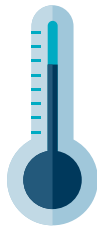

Dx-Series printers deliver up to 100% duty cycle at 45°C.

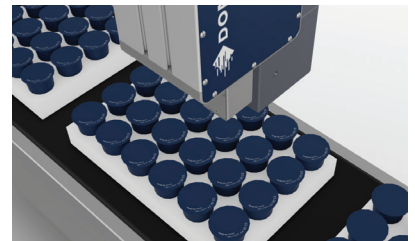

Special scanhead for large marking fields and wide web applications.

Ready for the 2D code evolution

GSI is driving a global initiative to transition retail from linear barcodes to GTIN-equipped 2D QR codes powered by GSI.

But there's more than just the GTIN. QR-codes powered by GSI can provide a huge range of supply chain and consumer-focused information with one code, revolutionizing the way information and interaction is enabled through product packaging:

Targeted information can be displayed to manufacturers, retailers, or consumers, enabling different levels of interaction with each.

Processes and data can be dynamically linked throughout the supply chain, allowing an individual product to be tracked throughout its complete life-cycle.

Brands can use the QR code to interact with their consumers while giving them all relevant information through a simple scan of the code with a smart phone.

All information is available from a single QR code, freeing up space on labels and packaging.

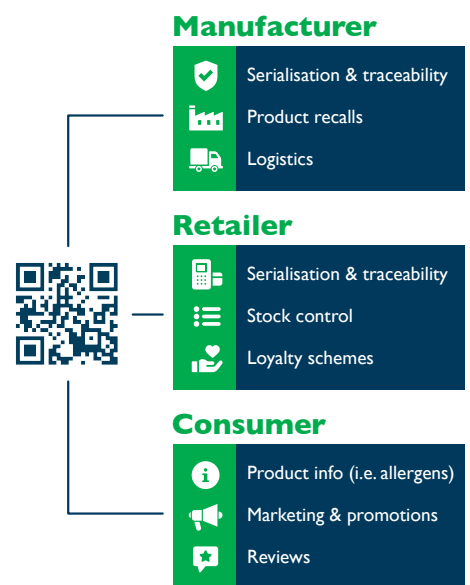

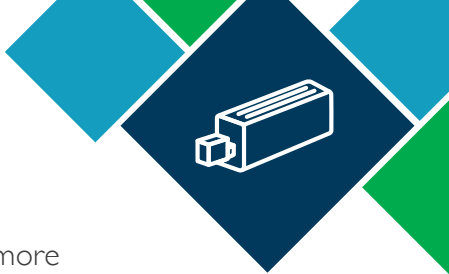

From a laser to a complete solution

At Domino, we understand that product coding and marking encompasses much more than just a printer, which is why we partner with our customers to develop end-to-end solutions that fit their production requirements. We take care of the whole process, including testing, training, installation, and support throughout the lifetime of the coding system. To meet the needs of modern manufacturing environments our coding solutions can include everything needed for a full code and check solution: coding automation, vision control, and remote monitoring and diagnostics, helping to ensure only perfectly coded products enter the supply chain.

- ◆ **Testing:** Our laser labs use a scientific approach to analyse substrates and samples to help ensure that we can find the ideal laser for your application.
- ◆ **For a perfect fit:** Domino offers bespoke customization of hardware, which includes the laser safeguarding, integration into ERP, WMS and MES systems, and a web-based user interface.
- ◆ **Safety is paramount when operating laser systems:** laser guarding, extraction to remove particles that can damage equipment and reduce code quality, correct installation, prevention of access in operation – we have you covered.
- ◆ **Support: Dx-Series** laser systems rarely need attention, but if they do, we're here to help: We utilize AR to troubleshoot issues remotely; should on-site support be needed, our technicians will come prepared to get your line running as fast as possible.



Scientific substrate analysis and sampling at Domino's laser labs.



Custom-made laser guarding; laser safety training courses are also available.



Domino's **DPX** fume extraction systems effectively filter fume and particulate debris from the coding process.

Our services are designed to provide operational insight so you can eliminate downtime and maximize production efficiency.



Operational support

An outstanding level of care, wherever you are. Our **SafeGuard** packages provide high-quality, on-site assistance and AR-enabled remote guidance from our engineers. **SafeGuard** helps to ensure we can be with you when you need us most.

Automatic code inspection

Ensure every code that leaves your factory is present and correct, and free up operator time. With the **R-Series**, Domino's range of vision control systems, you can automate your code inspection to validate code presence, placement, and readability.

Automation

Centralize your label management: **Domino Automation** easily integrates into your manufacturing process as well as your ERP/ MES systems. It makes automatic changeovers safe and simple, helping you to reduce waste and drive sustainability initiatives while increasing productivity and efficiency.

Smart production

Gain operational insight by connecting your printer to Domino's cloud-based services. Obtain production analytics dashboards and receive system error alerts. Our cloud service provides you with the information you need to run your operations more efficiently.

Our sustainability commitment

At Domino Printing Sciences, we believe that our responsibility extends beyond the products and services we provide. We aim at driving change in our sector by implementing an ambitious CSR strategy for our company and developing innovative solutions to help our customers become more sustainable. Learn more about our commitments and progress on our website.



Technical specification Dx-Series

Laser Type	Dx260i	Dx360i	Dx660i
Laser technology	CO ₂		
Laser source	20W, wavelengths 9.3, 10.2, 10.6µm	30W, wavelengths 9.3, 10.2, 10.6µm	60W, wavelengths 9.3, 10.2, 10.6µm
Expected lifetime	50,000h MTBF		
Coding Format			
Coding content	Laser optimized fonts for high-speed marking and standard industrial fonts. Graphics, logos, standard industrial machine readable code (1D, 2D) formats (Data Matrix, GSI, QR). Intuitive GSI Digital Link support. Supporting traceability with serialization data, sequential and batch numbering. Synchronised clock / Network Time Protocol support (NTP).		
Focal length	from 80mm to 600mm		
Marking field	from min. 57x57mm to max. 379x582mm		
Advanced features	Aiming beam, Aim & Code		
User Interface			
User interface	Web based user interface, option to configure multiple parallel access points, optional 10.1" touch panel		
Interface options	Domino Cloud interface (DCI), Domino Automation		
System Specification			
Scanhead orientations	Multitude of scanhead orientations including 360° rotatable variant. More than 50 beam orientation variants. Support for customization and solution integration.		
Ingress protection	Laser module: IP54 certified fan cooled, optional IP65 certified compressed air cooled Controller: IP55 certified	Laser module: IP54 certified fan cooled, optional IP65 certified water cooled Controller: IP55 certified	
Operating temperature	5°C-45°C at up to 100% duty cycle		
Operating humidity	max. 90% RH, non-condensing		
Electrical supply	multivoltage 90-264V, 50/60Hz		
Input and Outputs, Interfaces			
Inputs/outputs	Multiple inputs and outputs available e.g. extractor; compressed air kit, water chiller; encoder; product detect (NPN, PNP), beacon and interlocks, standard GPIO, additional optional GPIO available.		
Interfaces/protocols	Ethernet, USB, Dynamark Protocol, EtherNet/IP™		
Options			
Accessories	Extraction including optimized shrouds, airknife for lens cleaning, multiple brackets, cables, and stands for integration support		
Certification	Marking: CE**, cTUVus, UKCA / Fulfills requirement: NRTL, ROHS, FDA listed, EMC, FCC		

** Partly completed machinery as per Machinery Directive (2006/42/EC), CE marking according to ROHS (2011/65/EU) and EMC(2014/30/EU)

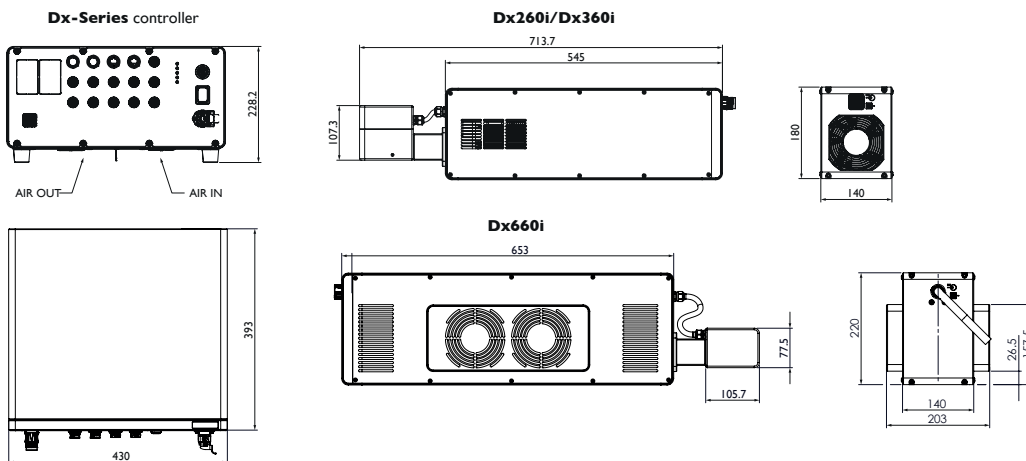

TALK TO AN EXPERT

800.444.4512
solutions@domino-na.com
www.domino-na.com